



Guidelines for the Application of the PPH PILOT
between
The National Directorate for Industrial Property of Uruguay
and the
Swedish Intellectual Property Office (PRV)

1. Background

These guidelines regulate the execution of the Memorandum of Understanding between the National Directorate for Industrial Property (DNPI) of the Ministry of Industry, Energy and Mining (MIEM) and the Swedish Intellectual Property Office (PRV) that entered into force on June 1st 2023.

The PPH Pilot aims to ensure the benefits of fast and economic high-quality examinations for the applications, avoiding the duplication of efforts and reducing the existing workload in the respective Offices, and promoting inter-office cooperation.

This guide establishes the conditions for using the PPH Pilot for those applications filed before DNPI.

2. Term of Application

The PPH Pilot (DNPI-PRV) will begin on June 1st, 2023 for an initial period of 3 (three) years.

3. Requisites for an accelerated examination under the PPH Pilot at DNPI.

Any application that pretends to use the PPH (PRV-DNPI) must comply with the following conditions:

3.1. The application filed with DNPI for which the PPH is requested and the application/s before PRV on which the application of the pilot is based must be corresponding patent filings, with the same initial date (priority or filing date) and the application before DNPI is:

- a. An application validly claiming priority under the Paris Convention in respect with, at least, one application filed before PRV.
- b. An application on which a priority under the Paris Convention is claimed for an application filed with the PRV.



- c. An application that claims priority from an international filing – via PCT- in which PRV acts as an ISA/IPEA.
- d. An application derived from a corresponding international filing in which PRV acts as an ISA/IPEA

The expression “corresponding patent filings” should not be interpreted necessarily as a filing on which a priority claim is based, but it could also refer to an application derived from the filing on which the priority claim is based; for example, a divisional application or an application that invokes national priority from the application on which priority is claimed.

3.2. That the corresponding filing has been subjected to substantive examination and one or more claims have been determined as patentable/acceptable by the PRV (in the course of normal duties or as an ISA/IPEA).

The applicant must identify the relation between the application filed at DNPI – for which the PPH is being petitioned – and the corresponding application/s filed at PRV, or the corresponding PCT filing where PRV acted as ISA/IPEA, that contains the claim/s declared patentable/acceptable.

The claim(s) declared as patentable/acceptable must be explicitly identified as such in the granted patent or in the most recent official action issued by PRV that serves as a basis for the petition for participation in the PPH pilot, even though the corresponding application has not yet been granted.

3.3. All claims in the application filed before DNPI, either as originally presented or modified, for examination under the PPH Pilot (PRV-DNPI) must be sufficiently corresponding with one or more claims declared as patentable/acceptable by the PRV.

Claims are considered “sufficiently corresponding” when, considering the differences due to translation and/or format, the claims filed with DNPI have the same or less scope than the claims considered patentable/acceptable by the PRV (either in the course of its normal duties or as ISA/IPEA). For example, a claim has less scope when the claim filed with the PRV or in the international PCT filing is modified, to be limited by an additional technical characteristic supported in the specification (description and/or claims) originally presented at DNPI.

A claim filed with DNPI that introduces a new/different category of claims than those considered patentable/acceptable by the PRV or in the international PCT filing is not considered as sufficiently corresponding.



It is not required to include “all” the claims considered patentable/acceptable by the PRV or in the international PCT filing (the deletion of claims is admitted). For example, if the application filed with the PRV contains 5 claims declared as patentable/acceptable, the application filed with DNPI may contain only 3 of those 5 claims.

This does not preclude the possibility of further amendments to the claims, insofar they are supported by the description and maintain the correspondence with the PRV claims, either by the applicant’s initiative or in response to an official request by DNPI.

Annex II shows illustrative examples of claims that are considered as “sufficiently corresponding” and claims that are not considered “sufficiently corresponding”.

Any claim amended or added after the petition for participation in the PPH Pilot (DNPI-PRV) must be sufficiently corresponding with the claims indicated as patentable/acceptable in order to benefit from the PPH accelerated examination.

3.4. The application filed with DNPI must have been published.

The application for which the PPH is being petitioned must have been published, the term for observations expired and be in condition for substantive patentability examination, in accordance with articles 26 and 31 Law 17.164 dated 02/09/1999 and articles 10, 11 and 12 Regulatory Decree 11/000, dated 13/01/00.

3.5. Substantive Examination

DNPI must have not notified a patentability examination of the application, in accordance with article 32 Law 17.164 and articles 13 Regulatory Decree 11/000, at the moment when the petition for participation in the PPH Pilot is filed.

4. Documents to file with DNPI for participation in the accelerated examination under the PPH PILOT (DNPI-PRV).

4.1. The applicant must accompany the corresponding form with the following documents:

- a) Copy of every official action relevant to determining the patentability of the application (Communication of Acceptance, substantive examination, etc.), issued by the PRV.
- b) Copy of all the claims declared as patentable/acceptable by the PRV.
- c) A table showing the correspondence between the claims filed with DNPI – for which the PPH Pilot is being requested – and the corresponding claims in the



PRV filing or international PCT filing where the PRV acted as IPEA, that have been declared patentable/acceptable

- d) Copy of the background, information, references or documents cited by the PRV examiner in the substantive examination, Communication of Acceptance or other official actions, including “non-patent” literature, which must always be filed by the applicant.

In case the patent documents are not available to DNPI, the applicant must provide said documentation, with the respective translations if necessary, at DNPI’s request.

4.2. If any of the documents mentioned in 4.1 have already been filed with DNPI, before the petition for participation in the PPH Pilot, it is not necessary to present said documents again with the request for the PPH Pilot. In that case it will be sufficient for the applicant to cite the document/s with their bibliographical data, mentioning when they were originally filed, with the request for PPH.

4.3. All documents for the PPH (e.g. official actions, etc.) should be filed in or translated to Spanish. In the case of documents in English, insofar both a Spanish and English version are filed together, machine translations are admissible.

5. Procedure for petitioning accelerated examination of an application filed with DNPI under the PPH Pilot (DNPI-PRV)

5.1. The applicant must present a petition for participation in the PPH Pilot (DNPI-PRV) accompanying the corresponding form and the documents mentioned in the previous section. The form must always be filed in Spanish.

Upon compliance with all the requisites for accelerated examination under the PPH a notification for the applicant shall be issued informing said circumstance, and the accelerated examination will be carried out.

Should the petition for accelerated examination be denied, the applicant will be notified and a second and only opportunity for re-petitioning will be available. In the eventuality that that second petition is also denied, the patent application will continue the normal procedure as appropriate. If the second petition is admitted, the applicant will be notified and the accelerated examination shall be carried out.

5.2. Acceptance for participation in the PPH Pilot is not transferable to a divisional application. The applicant may present a new petition for PPH Pilot in the divisional application, complying with the corresponding requisites.



5.3. Every modification made in the patent application claims, in order to be considered for the PPH Pilot, will come in effect at the moment it is made, irrespective of the granting or rejection of the PPH application.

5.4. Every brief, communication or correspondence related to the participation in the PPH Pilot filed with DNPI should be clearly identified as such, stamping the term PPH in the upper part of the first page, so that it may be adequately processed.

5.5. The PPH procedure does not exempt the applicants of all their obligations under the applicable legislation.



ANNEX I

Patent Applications that comply with the requisites for accelerated examination under the PPH Pilot (DNPI-PRV)

Example A: Paris Route.

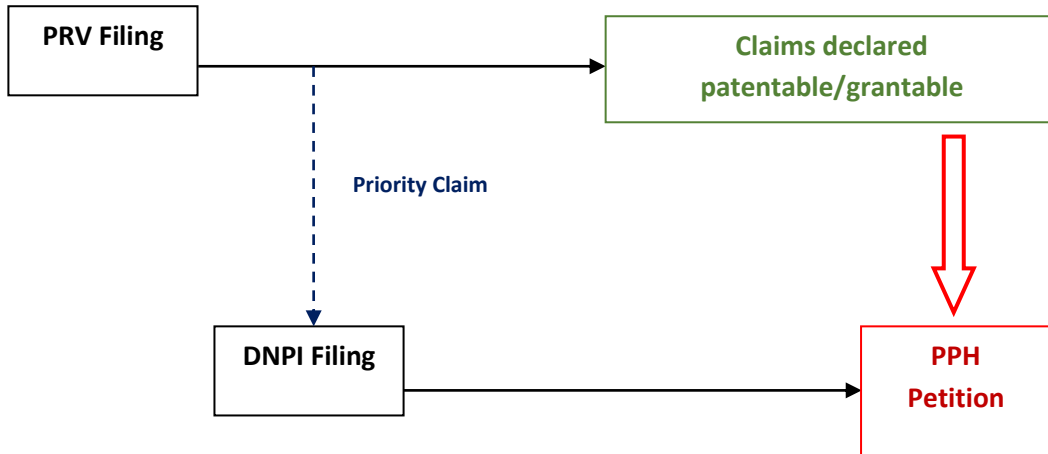

Example B: Paris Route and Complex Priority

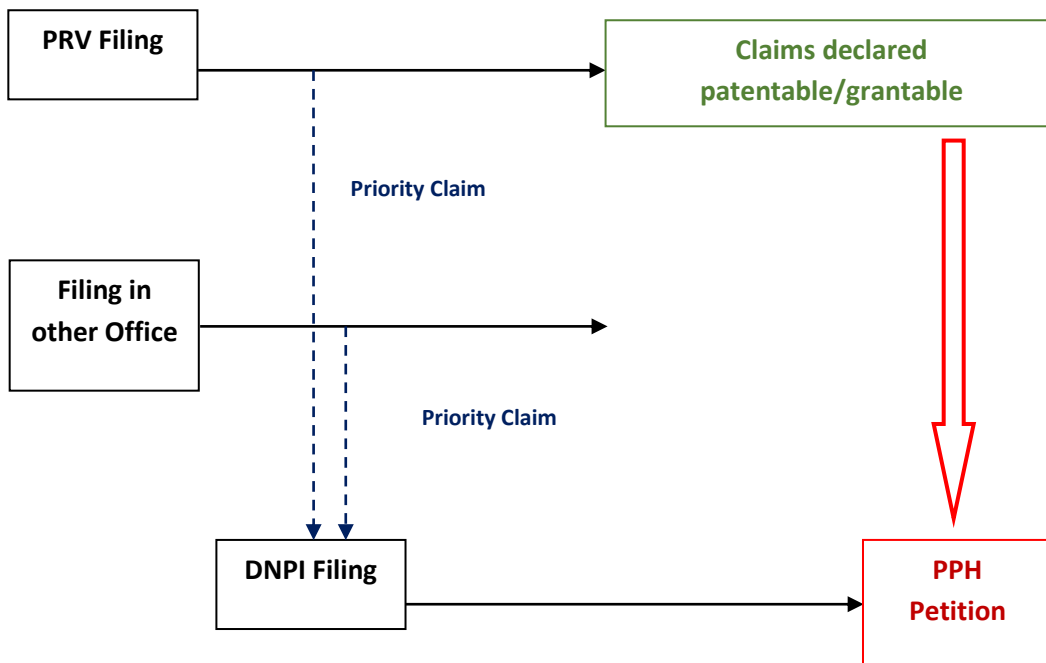



Example C: Paris Route and Divisionary Application

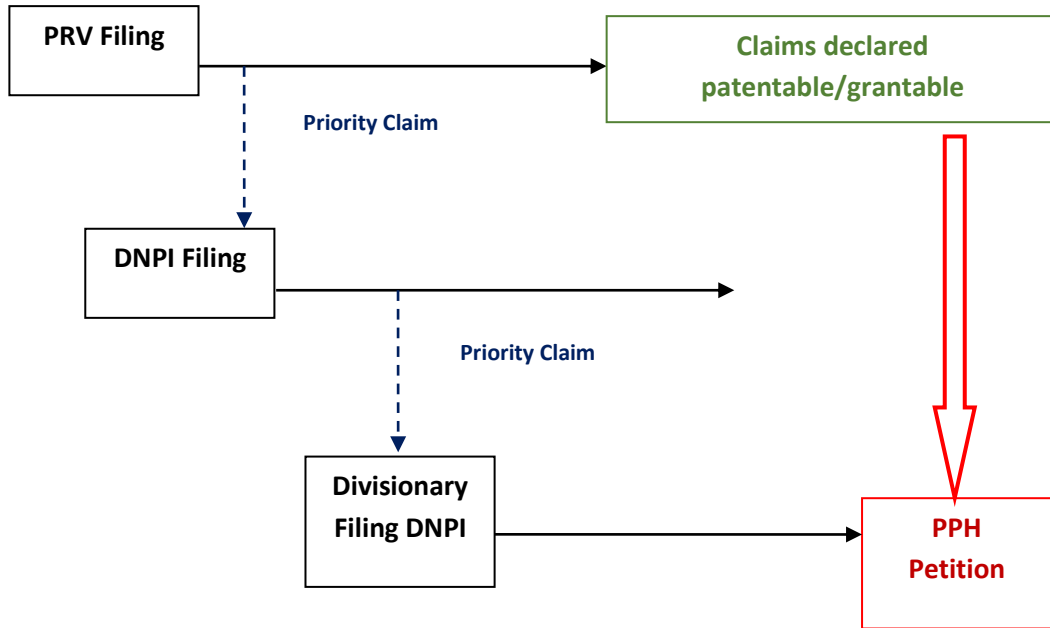

Example D: Paris Route

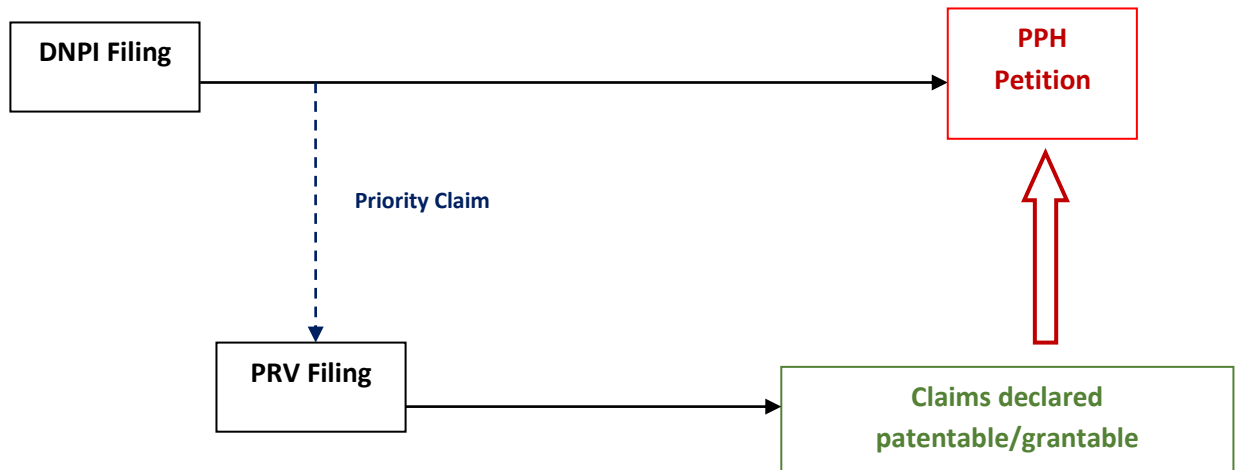



Example E: Paris Route and PCT

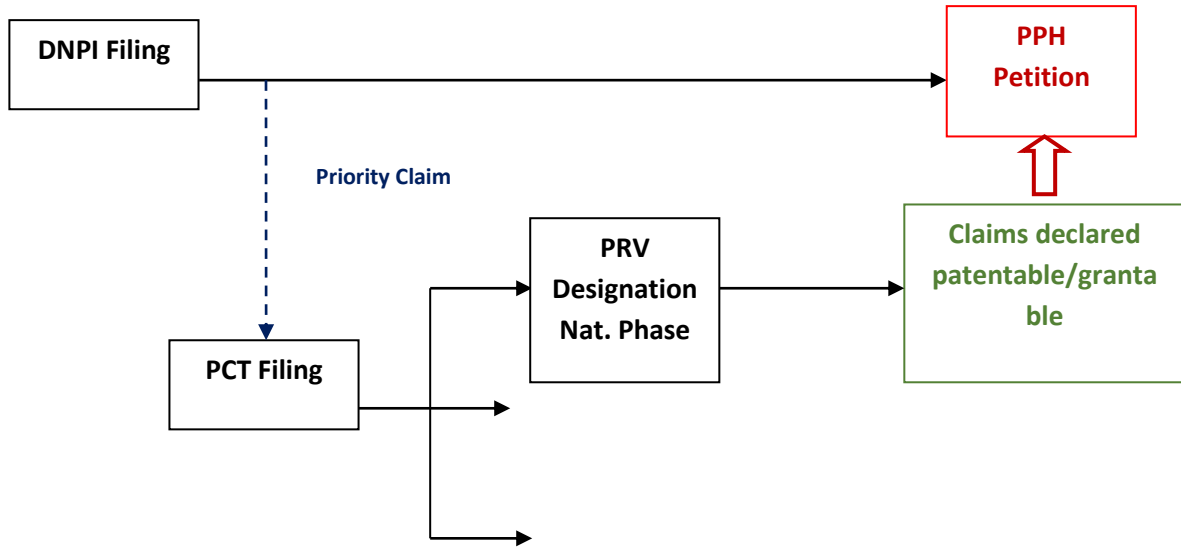

Example G: Paris Route and National Priority

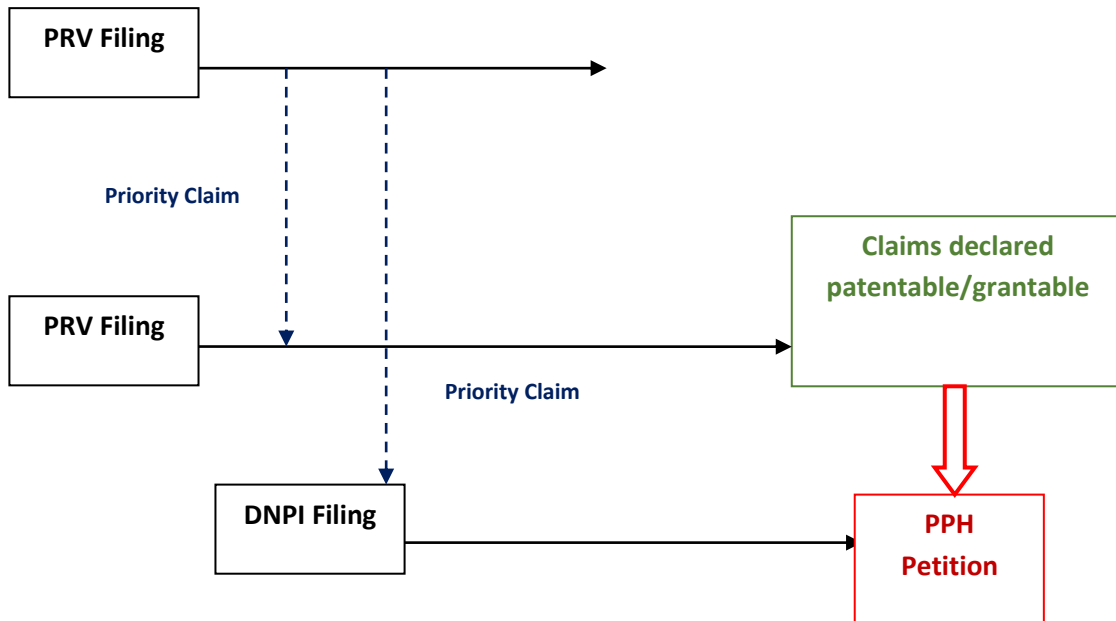



Example H: Paris Route and first filing in a third country

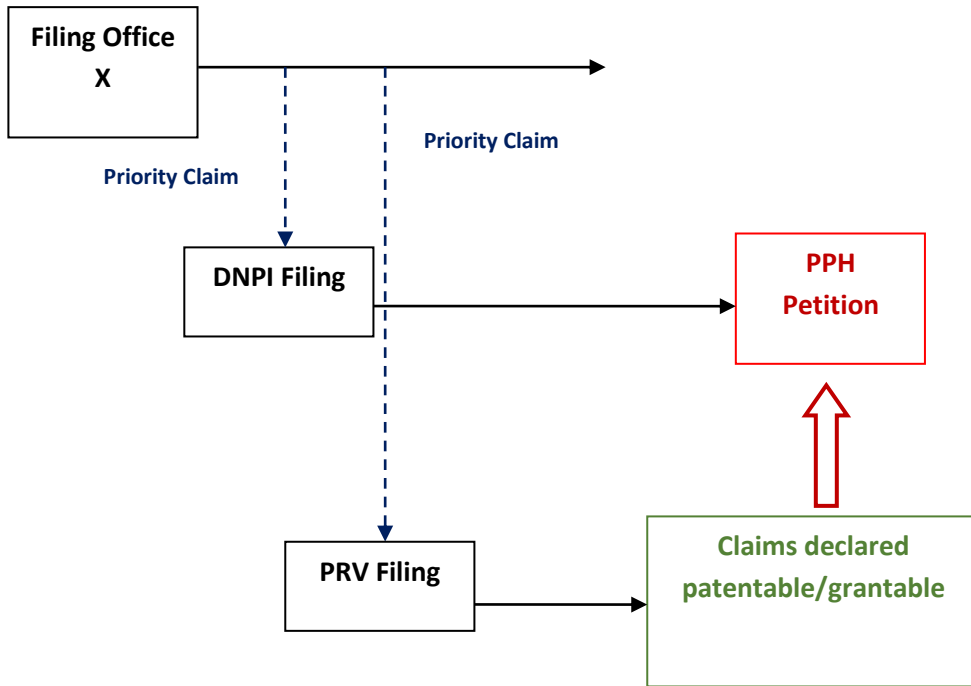

Example I: National Filing that serves as the basis for a PCT Filing

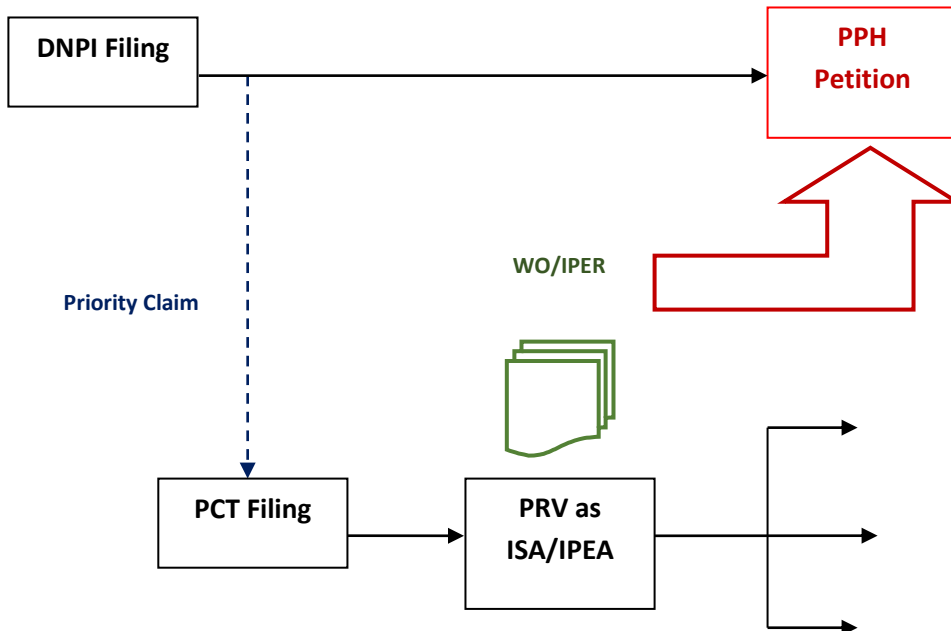



Example J: National Filing, claiming priority from a foreign international application

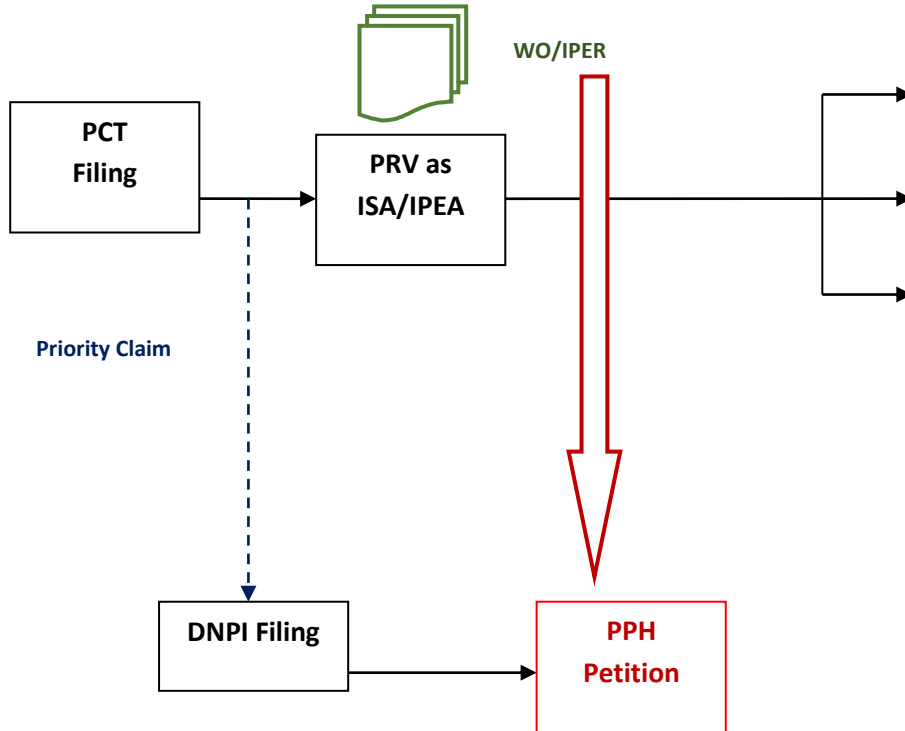



ANNEX II

Examples of cases where claims are considered “sufficiently corresponding” and cases that are not considered “sufficiently corresponding”

1. Claims in the following cases (1 to 4) are considered “sufficiently corresponding”:

Case	Claims patentable/grantable		Claim(s) filed with DNPI		Explanation
	No.	Content	No.	Content	
1	1	A	1	A	Claim 1 with DNPI is the same as Claim 1 declared “patentable/grantable”
2	1	A	1 2	A A+a	Claim 1 with DNPI is the same as Claim 1 declared “patentable/grantable” Claim 2 with DNPI is created by adding a technical characteristic described in the specification for Claim 1 “patentable/grantable”.
3	1 2 3	A A+a A+b	1 2 3	A A+b A+a	Claim 1 with DNPI is the same as Claim 1 declared “patentable/grantable” Claims 2 and 3 in DNPI are the same as claims 3, 2 declared “patentable/grantable”, respectively
4	1	A	1	A+a	Claim 1 with DNPI has an additional technical characteristic “a” described in the specification.



2. Claims in the following cases (5 & 6) are NOT considered sufficiently corresponding”:

Case	Claims patentable/grantable		Claim(s) filed with DNPI		Explanation
	No.	Content	No.	Content	
5	1	A Product	1	A' Method	Claim 1 filed with DNPI refers to a method in which Claim 1 “patentable/grantable” refers to a product. The technical characteristic of the claim “patentable/grantable” is the same as the claim filed with DNPI but the categories are different.
6	1	A+B	1	A+C	Claim 1 filed with DNPI is different than claim 1 “patentable/grantable” in one of the components of the claimed invention. Claim 1 filed with DNPI was created altering part of the technical characteristics of the “patentable/grantable” claim.